

		Date	2009-09-14	EPLAN		EPLAN Software & Service GmbH & Co. KG		POMIARY TEMPERATUR		= CA1	
		Ed.	Mietek	Basic project with IEC identifier structure						+ EAA	
Modification	Date	Name	Original	Replaced by	Replaced by			IEC_bas001		Page	3
										Page	7

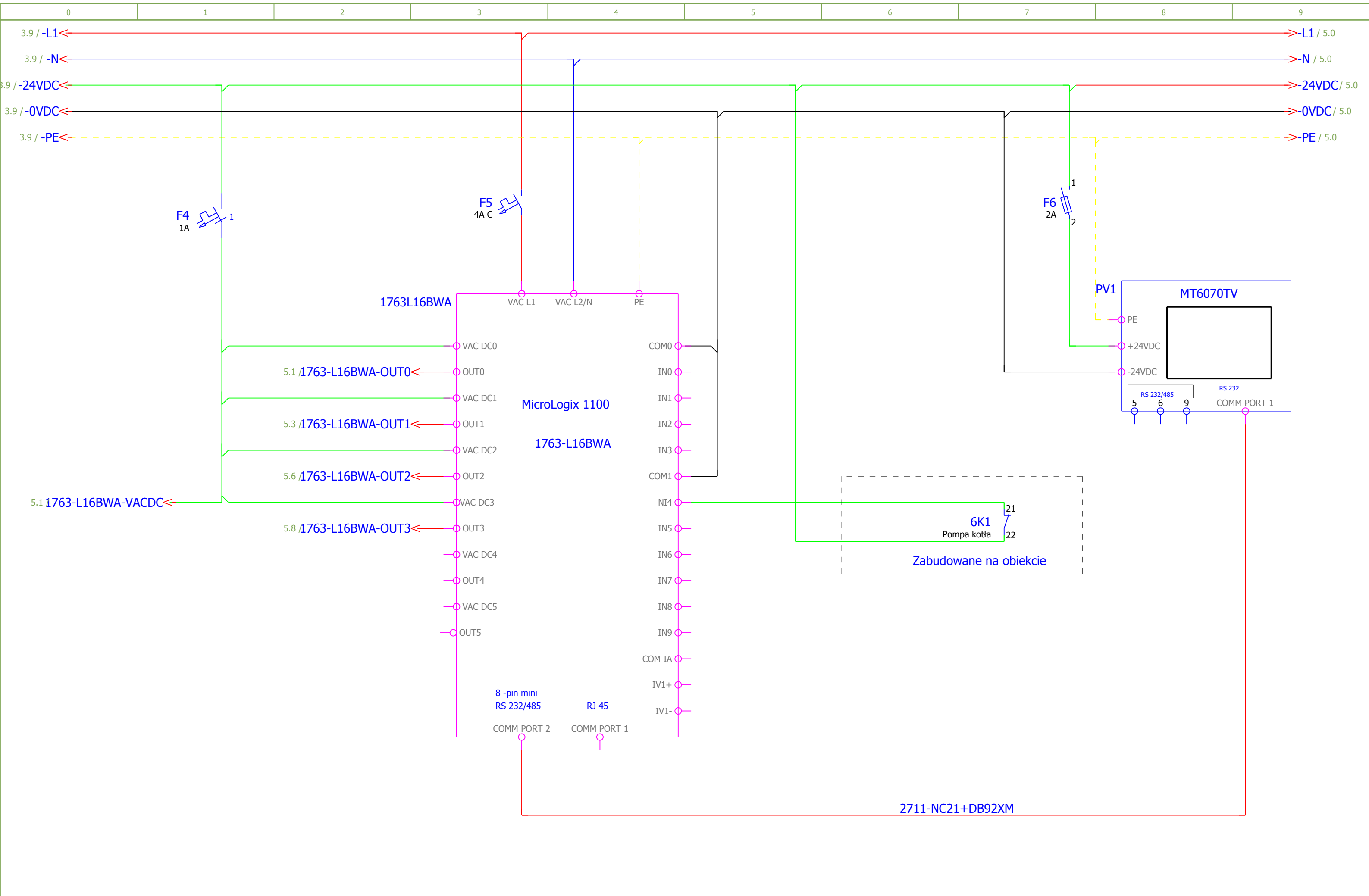

3			Date: 2009-09-11		EPLAN		EPLAN Software & Service GmbH & Co. KG		PLC		= CA1 + EAA		Page 4	
			Ed.: Mietek		Basic project with IEC identifier structure						IEC_bas001		Page 7	
Modification			Date		Name		Original		Replaced by		Replaced by			

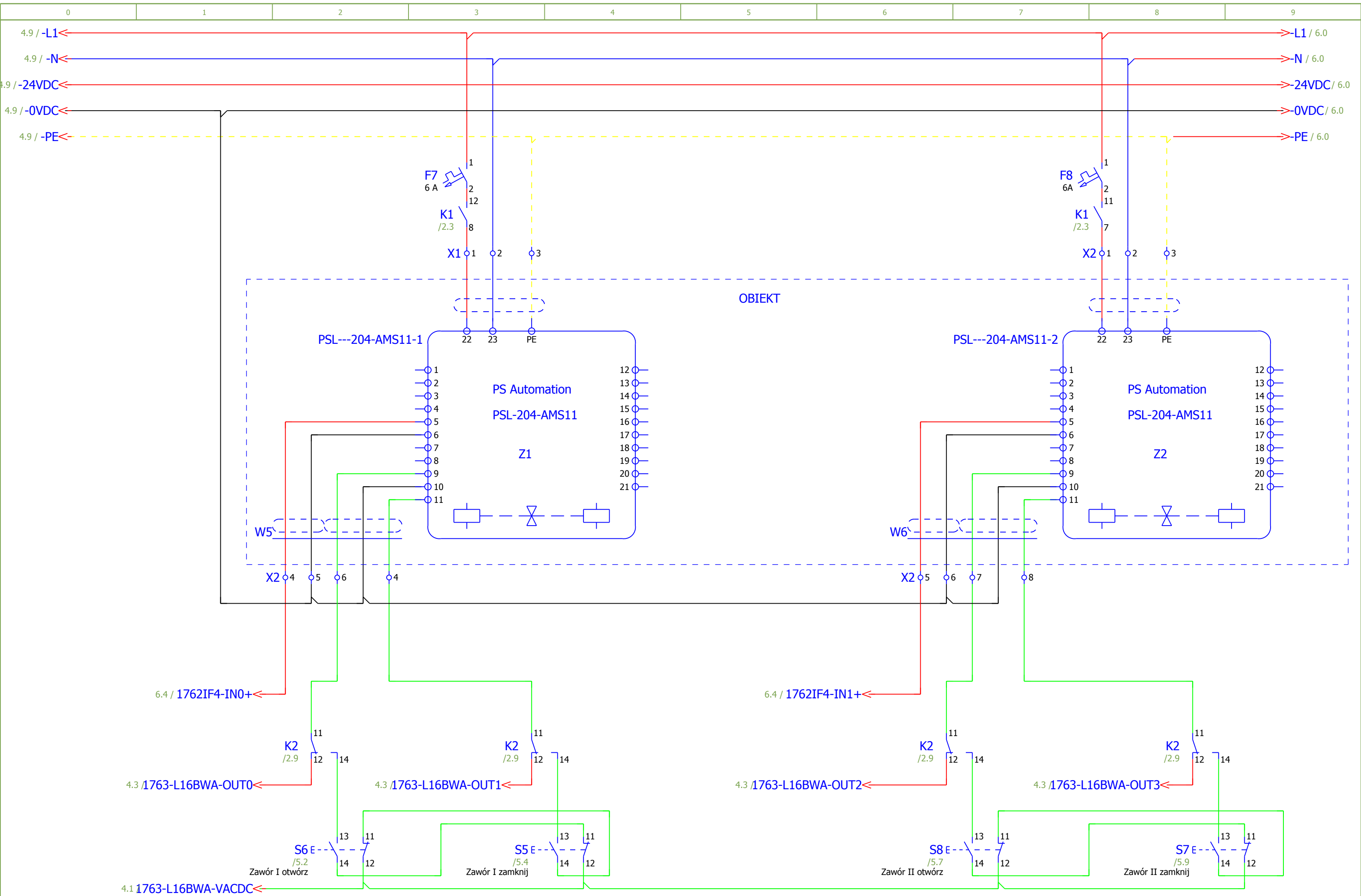

			Date	2009-09-14	EPLAN		EPLAN Software & Service GmbH & Co. KG		SIŁOWNIK ZAWORU I i II		= CA1	
			Ed.	Mietek	Basic project with IEC identifier structure						+ EAA	
			Appr		Replaced by		Replaced by				IEC_bas001	
Modification	Date	Name	Original								Page 5	
											Page 7	

